

Wireless Charging Transmitter Coil Assembly for Wearables and Small Electronic Device



FEATURES



- Assembled with 3D-shaped ferrite shielding and Litz coil
- For low power application (up to 1.5A or 5W)
- Compatible with tightly coupled charging standard (e.g., WPC)
- Wide operating temperature -40°C to +85°C

APPLICATIONS

- Wireless power transmitter for wearables, electronic gadgets, smart car keys (FOB), small medical devices that requires contactless charging for convenience, hygiene or water proof
- General low power wireless charging applications requires contoured ferrite for better efficiency in limited space

ELECTRICAL SPECIFICATIONS

PART NUMBER	INDUCTANCE (μH)			DCR Max (mΩ)
	MIN	NOM	MAX	
RWC2727AH070-300	5.00	5.50	6.00	48.3

1. Inductance tested at 200KHz, 1V
2. Operating temperature range: -40°C ~ +85°C (Including self-heating)
3. Storage temperature range (packaging conditions): -10°C ~ +40°C and RH 70%(MAX)

SHAPES AND DIMENSIONS

Unit:mm

A	C	D
27.00±0.40	4.20 Max.	49.36±3.00
E	F	
7.00 Typ.	10.00±2.00	

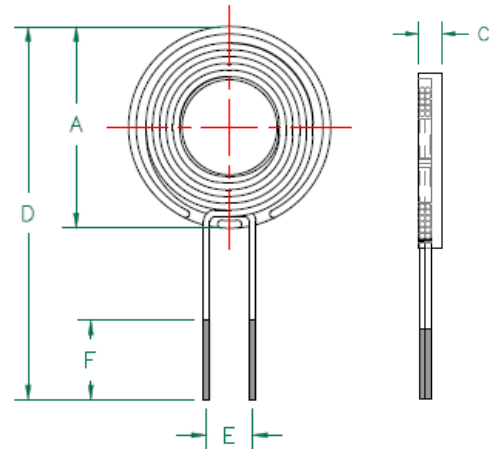

PART NUMBER SYSTEM EXAMPLE

<u>RWC</u>	<u>2727</u>	<u>AH</u>	<u>070</u>	-	<u>300</u>
Coil Type	Part Size Code	Height Code	Inductance Code		Catalog or Custom Information

USA: +1.423.308.1690
Europe: +42.0.4885.7511.1
Asia: +86.757.2563.8860

MCP-DS-WPC TX COIL ASSEMBLY MODULE 102816

Any information furnished by Laird Technologies, Inc. and its agents is believed to be accurate and reliable. All specifications are subject to change without notice. Responsibility for the use and application of Laird Technologies materials rests with the end user. Laird Technologies makes no warranties as to the fitness, merchantability, suitability or non-infringement of any Laird Technologies materials or products for any specific or general uses. Laird Technologies shall not be liable for incidental or consequential damages of any kind. All Laird Technologies products are sold pursuant to the Laird Technologies' Terms and Conditions of sale in effect from time to time, a copy of which will be furnished upon request. © Copyright 2014 Laird Technologies, Inc. All Rights Reserved. Laird, Laird Technologies, the Laird Technologies Logo, and other marks are trademarks or registered trademarks of Laird Technologies, Inc. or an affiliate company thereof. Other product or service names may be the property of third parties. Nothing herein provides a license under any Laird Technologies or any third party intellectual property rights. Version A01