

# IC0603A681R-10

## PHYSICAL DIMENSIONS:

|   |             |               |
|---|-------------|---------------|
| A | 1.60 [.063] | + 0.15 [.006] |
| B | 0.80 [.031] | + 0.15 [.006] |
| C | 0.80 [.031] | + 0.15 [.006] |
| D | 0.30 [.012] | + 0.20 [.008] |

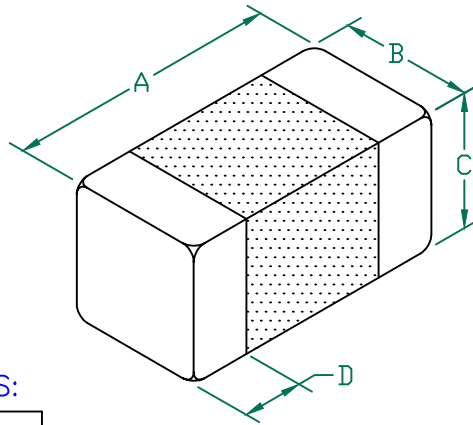

- NOTES: UNLESS OTHERWISE SPECIFIED
1. TAPED AND REELED per CURRENT EIA SPECIFICATIONS 7" REELS, 4000 PCS/REEL, PAPER TAPE.
  2. TERMINATION FINISH IS 100% MATTE Sn OVER Ni.
  3. COMPONENTS SHOULD BE ADEQUATELY PREHEATED BEFORE SOLDERING.
  4. I (MAX.) IS BASED ON THE MAXIMUM SUSTAINED CURRENT APPLIED WHILE MAINTAINING A MAXIMUM TEMPERATURE RISE OF 40°C OVER AMBIENT.
  5. OPERATING TEMP. RANGE: -40°C~+125°C. (INCLUDING SELF-HEATING)
  6. COSMETIC SPECIFICATION REFER TO WI-QA-124.

## ELECTRICAL CHARACTERISTICS:

|                          |        |     |
|--------------------------|--------|-----|
| L (nH)<br>± 10%          | 748    | Max |
|                          | 680    | Nom |
|                          | 612    | Min |
| Q (Min)                  | 15     |     |
| Freq. (MHz)              | 25     |     |
| Self-Resonant Freq (MHz) | 80 Min |     |
| DCR(Max)<br>$\Omega$     | 1.70   |     |
| I (Max)                  | 75mA   |     |

## LAND PATTERNS FOR REFLOW SOLDERING

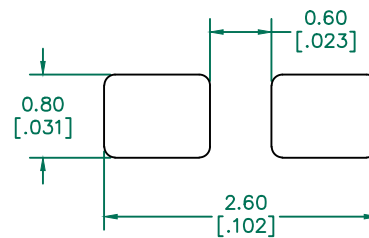

(For wave soldering, add 0.762 [.030] to this dimension)

## RECOMMENDED SOLDERING CONDITIONS

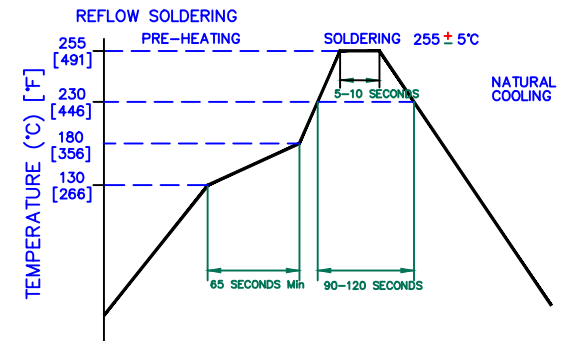

|                                |   |          |     |   |  |            |                    |               |
|--------------------------------|---|----------|-----|---|--|------------|--------------------|---------------|
| DIMENSIONS ARE IN mm [INCHES]. |   |          |     | This print is the property of Laird Tech. and is loaned in confidence subject to return upon request and with the understanding that no copies shall be made without the written consent of Laird Tech. All rights to design or invention are reserved. |  |            |                    |               |
| F                              | REMOVE NOTE 5 AND SRF   | 07/21/16 | QU  | PROJECT/PART NUMBER:<br>IC0603A681R-10  |  | REV: F     | PART TYPE: CO-FIRE | DRAWN BY: JRK |
| E                              | ADD OPERATING TEMPERATURE UPDATE LAIRD LOGO AND REFLOW CURVE            | 08/05/13 | QU  | DATE: 04/27/04  |  | SCALE: NTS | SHEET: 1 of 1      |               |
| D                              | UPDATE COMPANY LOGO   | 04/01/08 | JRK | CAD # IC0603A681R-10-F  |  | TOOL # -   |                    |               |
| C                              | MODIFY NOTES, CHG D DIMS & TOLS CHANGE SELF-RESONANT FREQ.              | 01/16/07 | JRK |   |  |            |                    |               |
| B                              | CHG P/N ADD @35mA TO MIN L&ADD I (OPERATING) TO ELECT BOX REV/ADD NOTES | 12/29/05 | TMB |   |  |            |                    |               |
| A                              | ORIGINAL DRAFT  | 04/27/04 | JRK |   |  |            |                    |               |
| REV                            | DESCRIPTION   | DATE     | INT |   |  |            |                    |               |