

# HI2220R181R-10

## PHYSICAL DIMENSIONS:

A	5.59 [.220]	+	0.51 [.020]
B	5.08 [.200]	+	0.25 [.010]
C	1.80 [.071]	+	0.25 [.010]
D	0.76 [.030]	+	0.25 [.010]

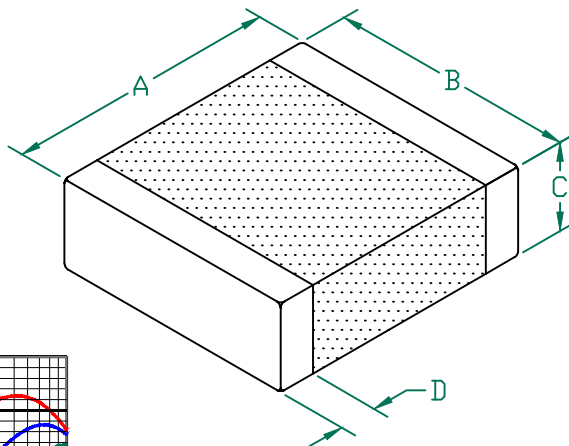

## ELECTRICAL CHARACTERISTICS:

Z @ 100MHz ( $\Omega$ )	DCR ( $\Omega$ )	Rated Current
Nominal	180	
Minimum	135	
Maximum	225	0.020
		5000 mA

NOTES: UNLESS OTHERWISE SPECIFIED

1. TAPED AND REELED per CURRENT EIA SPECIFICATIONS 13" REELS, 2,000 PCS/REEL.
2. TERMINATION FINISH IS 100% TIN.
3. COMPONENTS SHOULD BE ADEQUATELY PREHEATED BEFORE SOLDERING.
4. OPERATEING TEMPERATURE TEMP:  $-40^{\circ}\text{C} \sim +125^{\circ}\text{C}$  (INCLUDING SELF-HEATING)

Z vs. FREQUENCY  
IMPEDANCE UNDER DC BIAS

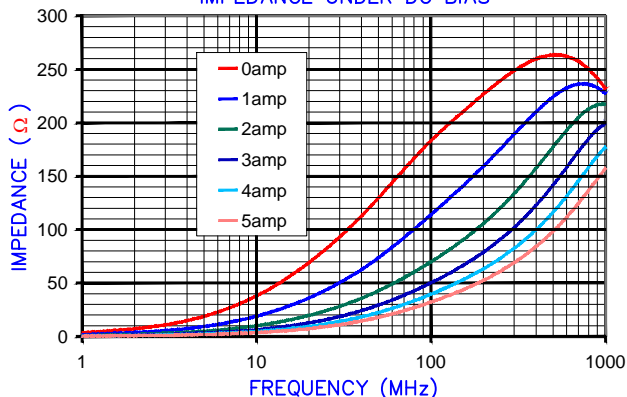

|Z|, R, AND XL vs. FREQUENCY

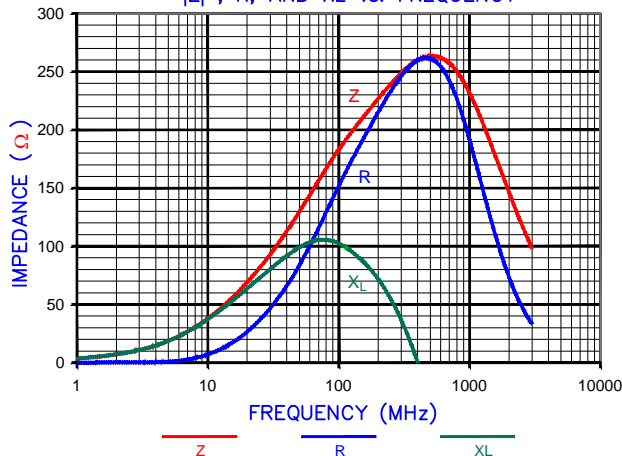

## LAND PATTERNS FOR REFLOW SOLDERING

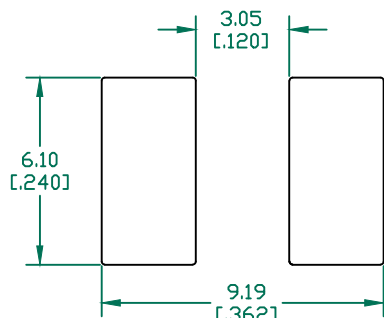

(For wave soldering, add 0.762 [0.030] to this dimension)

## RECOMMENDED SOLDERING CONDITIONS

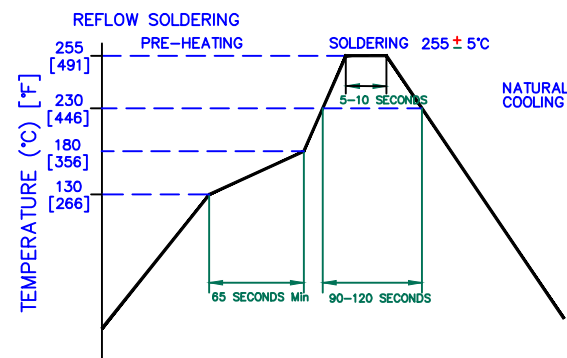

DIMENSIONS ARE IN mm [INCHES].				This print is the property of Laird Tech. and is loaned in confidence subject to return upon request and with the understanding that no copies shall be made without the written consent of Laird Tech. All rights to design or invention are reserved.			
C	ADD OPERATING TEMPERATURE UPDATE LAIRD LOGO AND REFLOW CURVE	08/05/13	QU	PROJECT/PART NUMBER:	HI2220R181R-10	REV	C
B	UPDATE COMPANY LOGO ADD ROHS	01/25/08	JRK	DATE:	04/03/04	SCALE:	NTS
A	ORIGINAL DRAFT	04/03/04	TMB	CAD #		TOOL #	-
REV	DESCRIPTION	DATE	INT		HI2220R181R-10-C		
						PART TYPE:	CO-FIRE
						DRAWN BY:	TMB
						SHEET:	1 of 1

