

Tflex HD90000 Thermal Reliability Report

Summary

The Laird Technologies' gap filler reliability test procedure has been designed to characterize the long-term performance of a gap pad while being subjected to isothermal conditions, repeated extremes in temperature, and moderate heat - high humidity environments. Specimens are placed within application-related fixtures under set conditions and at regular intervals the thermal properties of the specimens are measured.

Fixture Setup

The test fixture is rectangular with dimensions of 2" x 5" (surface area of 10 in²). It consists of an aluminum heater plate and an extruded aluminum heat sink "cooler plate". The heater plate contains 3 holes for insertion of cartridge heaters. Both plates contain 3 sets of thermocouple holes drilled for measurement of the temperature very near the surfaces mated by the gap pad. Each test fixture accommodates 3 test positions. The heater and cooler plates are held together by metal straps which span the width of the plates (2 sets per test fixture) and are bolted to each other. Cartridge heaters are inserted into the heater plate holes. A specified power from a power supply is input to the heaters to obtain a constant 70⁰C across the heater plate. This will ensure a constant heat flow is maintained through the gap filler during data acquisition. A cooling fan (not pictured) is centered on top of the heat sink during testing to facilitate realistic air flow and cooling. Test values are measured in an ambient laboratory environment.

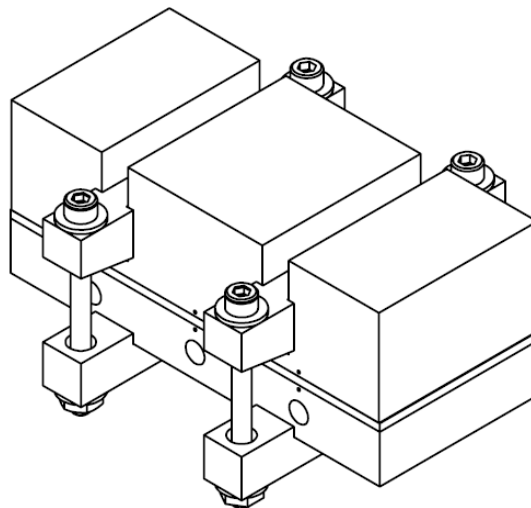

Tflex HD90000 Thermal Reliability Report

Theory

Throughout the test period, the measured variable is the temperature difference of the surfaces of the heater and cooler plates. Thermal resistance (R_{th}) is defined as the temperature difference (ΔT) between two surfaces for a given heat flow (ΔP). That is: $R_{th} = \Delta T / \Delta P$. In this testing, heat flow is controlled and constant, therefore, $R_{th} \propto \Delta T$. This relationship indicates that a constant value of ΔT throughout the test program requires R_{th} to also remain constant, which indicates a highly reliable system and thus a gap pad that is not influenced by the test conditions.

Types of Reliability Testing

Thermal Shock

In thermal shock testing, the test fixtures containing the specimens are transitioned between -50°C and 200°C with a 1 hour hold to reach thermal equilibrium at each temperature extreme. The transfer time between the oven temperatures is quick, typically less than 20 seconds. 1000 cycles "Shocks" are performed on each fixture.

Isothermal Bake

In isothermal bake testing, fixtures are maintained at 125°C for 1000 hours.

HAST

In HAST testing, the fixtures are maintained in conditions of moderate temperature (85°C) and high humidity (85%) for the duration of the test.

Results

The thicknesses of Tflex HD90000 tested were 40mil (1.016mm), 100mil (2.54mm), and 200mil (5.08mm). Two fixtures for each thickness were assembled and tested for all three reliability testing types (3 test positions for each unit). The data reported is the average of each value for the two fixtures.

The change in temperature (ΔT) vs. time / # of cycles tested is reported below:

Tflex HD90000 Thermal Reliability Report

Thermal Shock

Tflex HD90000 Delta Temperature over 1000 cycles of -50°C to 200°C

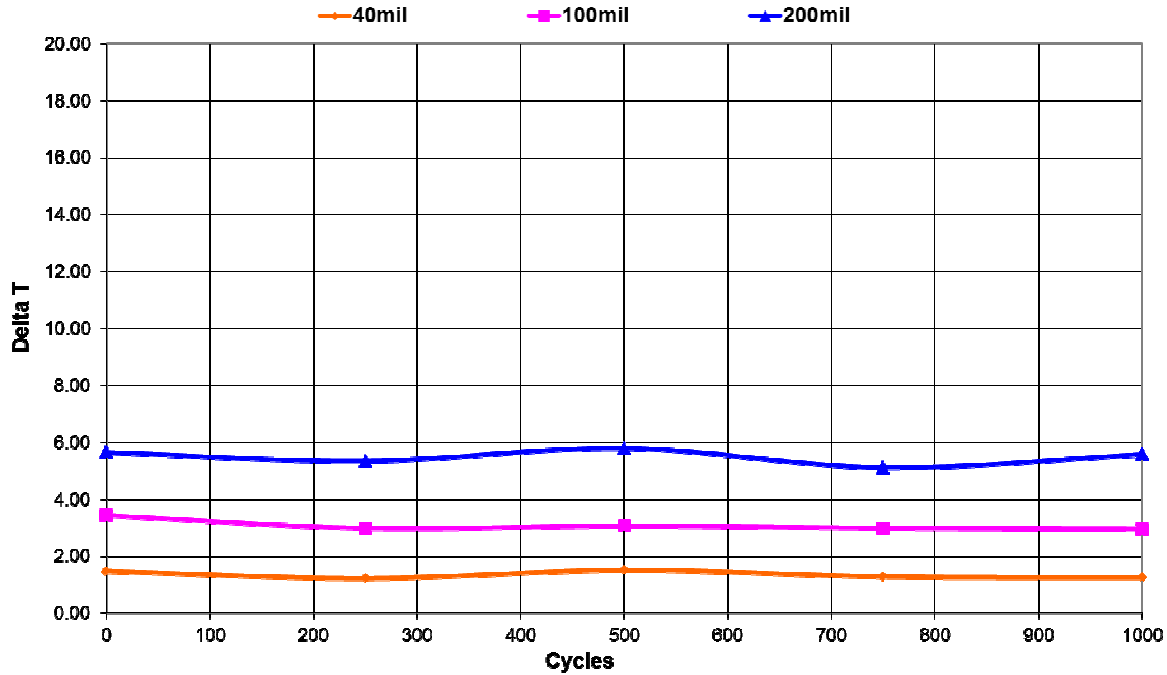

Material	Cycles	Avg ΔT
Tflex HD91000	0	1.47
Batch#000001	250	1.23
	500	1.51
	750	1.29
	1000	1.26
Tflex HD92500	0	3.44
Batch#000001	250	2.99
	500	3.07
	750	2.99
	1000	2.96
Tflex HD95000	0	5.65
Batch#000001	250	5.35
	500	5.79
	750	5.12
	1000	5.58

Tflex HD90000 Thermal Reliability Report

Isothermal Bake

Tflex HD90000 Delta Temperature over 1000 hours at 125°C

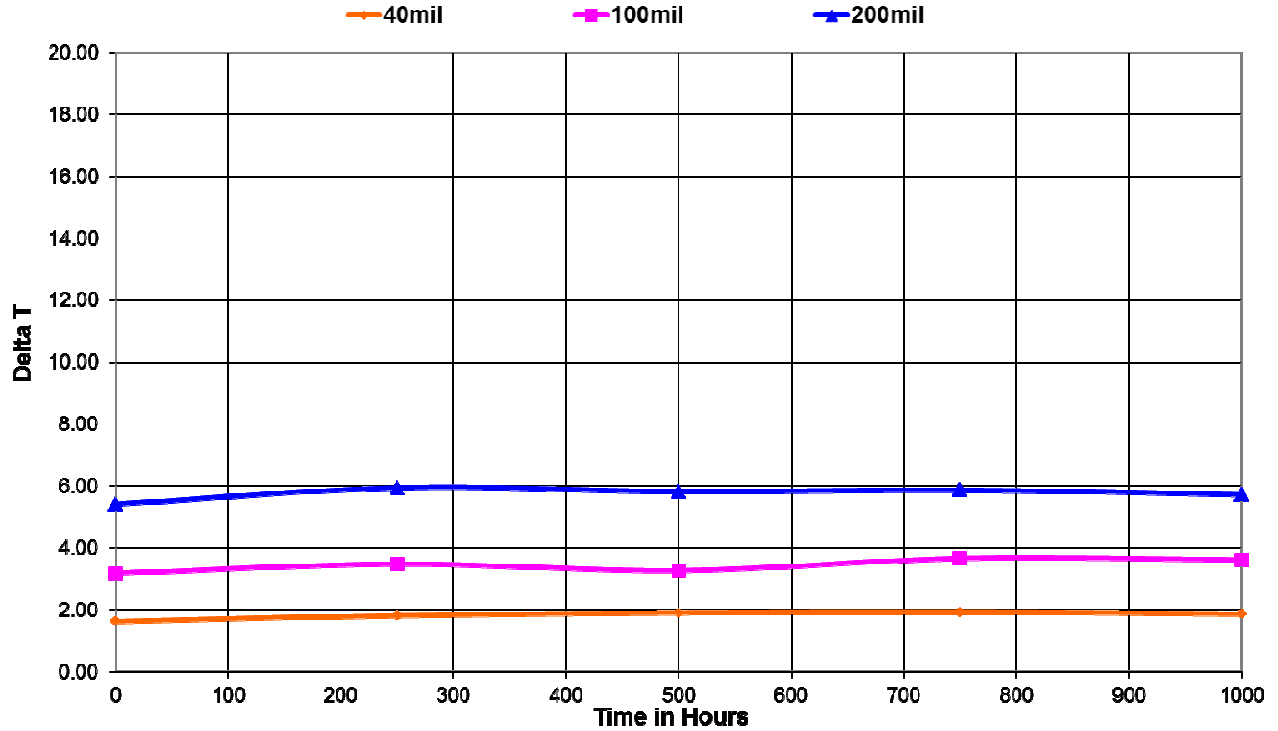

Material	Hours	Avg ΔT
Tflex HD91000	0	1.63
Batch#000001	250	1.81
	500	1.90
	750	1.92
	1000	1.86
Tflex HD92500	0	3.18
Batch#000001	250	3.48
	500	3.27
	750	3.66
	1000	3.62
Tflex HD95000	0	5.41
Batch#000001	250	5.94
	500	5.83
	750	5.87
	1000	5.72

Tflex HD90000 Thermal Reliability Report

HAST

Tflex HD90000 Delta Temperature over 1000 hours at 85% humidity and 85°C

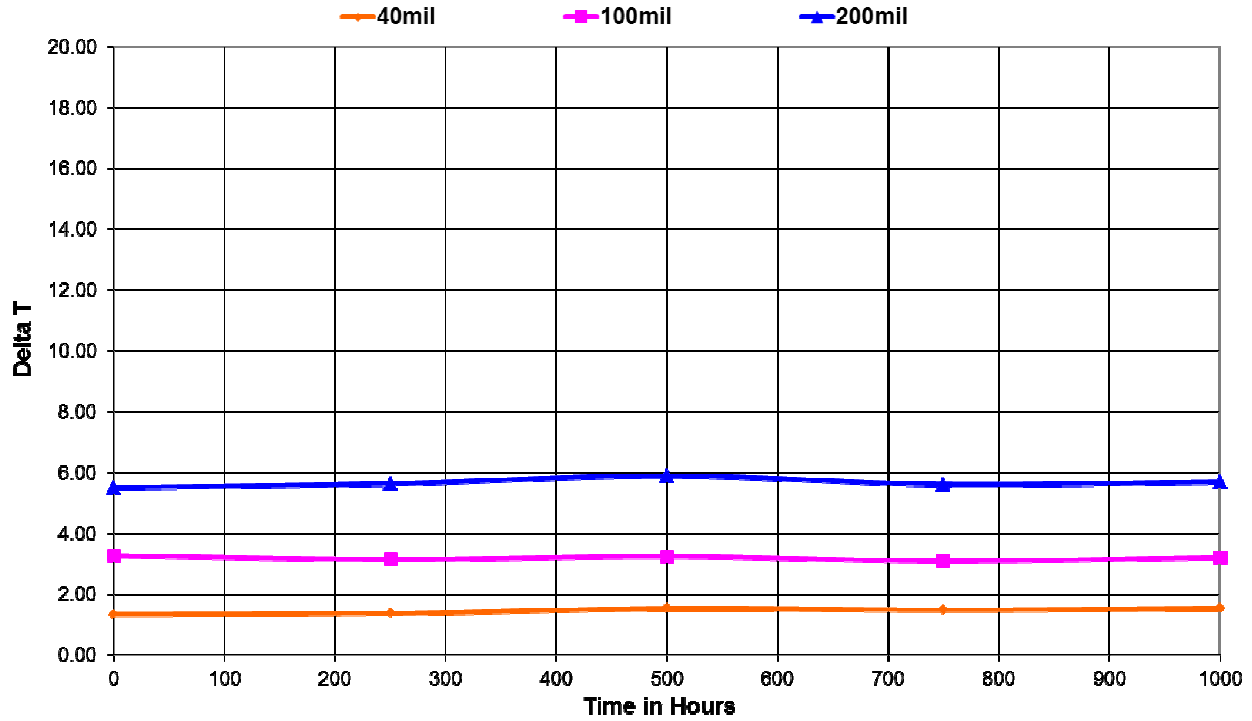

Material	Hours	Avg ΔT
Tflex HD91000	0	1.34
Batch#000001	250	1.38
	500	1.54
	750	1.49
	1000	1.54
Tflex HD92500	0	3.27
Batch#000001	250	3.15
	500	3.24
	750	3.10
	1000	3.21
Tflex HD95000	0	5.51
Batch#000001	250	5.64
	500	5.89
	750	5.62
	1000	5.70

Tflex HD90000 Thermal Reliability Report

Conclusion:

As the graphs and data show, Tflex HD90000 performed consistently throughout the reliability testing program. No thermal degradation was evidenced for Tflex HD90000 under conditions of constant elevated temperature, thermal cycling, or a combination of high heat and high humidity. Therefore, it is shown that Tflex HD90000 will continue to perform as designed in long term applications under harsh environmental conditions such as these.

Revision Log

Rev.	Summary of Change	Requested By	Approval Date
A	Initial Release	Mandy Feng	4/18/2017