

8	7	6	5
BASE PART NUMBER	THICKNESS	MATERIAL	STANDARD LENGTH PART NUMBER
0097-0555 (STANDARD)	0.076 ± 0.005 [0.0030]	BeCu ALLOY 25 TH02	0097055502
0098-0555 (ULTRASOFT)	0.051 ± 0.005[0.0020]	BeCu ALLOY 25 TH02	0098055502

PLATING CODE TABLE	
NUMBER CODE	PLATING TYPE
02	BRIGHT FINISH
17	BRIGHT TIN
19	BRIGHT NICKEL
MORE PLATING OPTIONS AVAILABLE CONTACT LAIRD SALES FOR DETAILS	

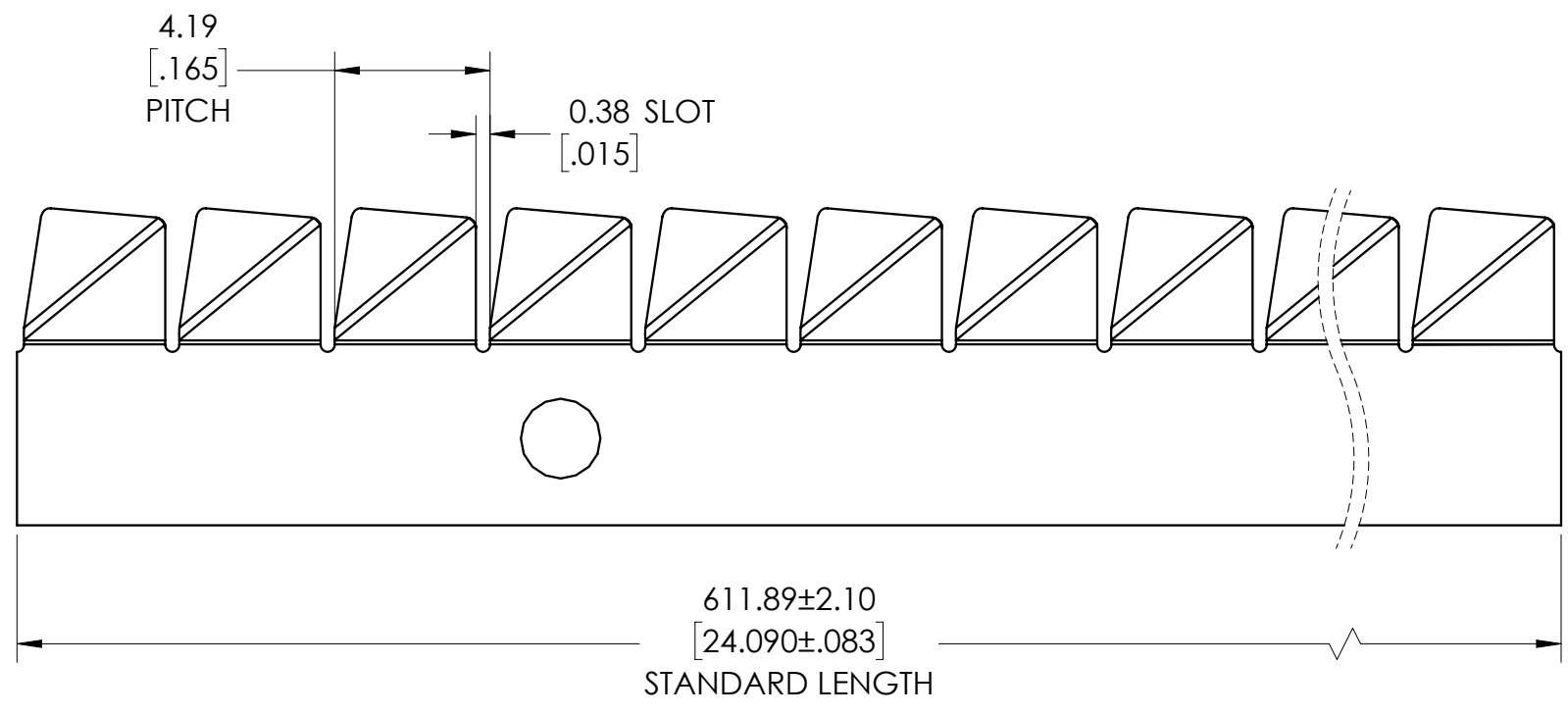

CUSTOM LENGTHS AVAILABLE IN MULTIPLES OF PITCHES OR "FINGERS"
 LENGTH = PITCH X N
 WHERE 'PITCH' IS 4.19 AND 'N' IS NUMBER OF PITCHES
 EXAMPLE: 43 x 4.19 = 180.17MM LONG
 SEE BOTTOM LEFT FOR CUSTOM LENGTH PART NUMBERING

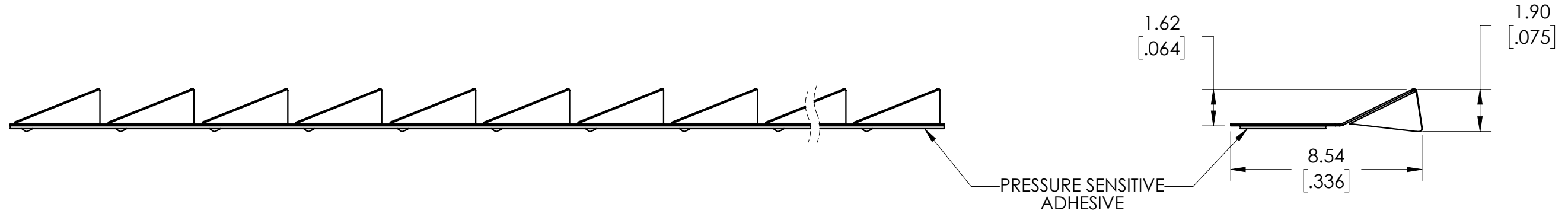

CUSTOM LENGTH PART NUMBER CONFIGURATION:
 009X 0555 XX X OXXXX

7 FOR STANDARD
8 FOR ULTRASOFT

PLATING CODE
(SEE TABLE)

LENGTH IN MM TO
ONE DECIMAL PLACE

N FOR NO ADHESIVE
T FOR ADHESIVE

EXAMPLE: 0098055517N01802
 ULTRASOFT, BRIGHT TIN PLATING, NO TAPE, 180.17MM LONG (43 FINGERS)

UNITS: MM [INCH]	Laird	LAIRD DRAWING NUMBER: 0097-0555-SALES
TOLERANCES: X.X = ± 0.4 X.XX = ± 0.2 X.XXX = ± 0.1		THIS IS AN UNCONTROLLED SALES DRAWING. THE DIMENSIONAL CHARACTERISTICS AND TOLERANCES OF THIS PART SHOWN ON THIS DRAWING AS A REFERENCE TO THE DIMENSIONAL SPECIFICATIONS OF THE LAIRD STANDARD PRODUCTION DRAWING FOR THIS PART. ANY SUBSEQUENT CHANGES TO THE STANDARD PART SPECIFICATION WILL SUPERSEDE THIS SALES DRAWING.
ANGULAR: X° = ± 3° X.X° = ± 1.0°	3RD ANGLE PROJECTION	DESIGNED IN SOLIDWORKS
	SCALE: 5:1	SHEET 1 OF 1
		SIZE B