



TYS -Low Profile SMT Power Inductor

TYS2520 Series

FEATURES AND APPLICATIONS

Laird TYS series high current power inductors improve performance, reliability and power efficiency. A lower profile benefits consumer electronics, industrial and telecom design. Products feature extremely low DCR with greater efficiency and enable a large current in a small size. Inductors are of magnetic shielding and wire wound construction and perform in operating temperatures ranging from -40°C to 125°C including self-heating rise in temperature.

FEATURES

- Magnetic shielded structure
- Low DCR and high efficiency
- Low profile and small size
- Ferrite core with high saturation



APPLICATIONS

- DC-DC Converter and Power Suppliers
- LCD TV'S and Gaming Console
- Tablet, Notebooks, Servers and Printers
- Networking and Data storage
- GPS, Set-top-box and Base stations
- Smart meters and Medical instruments

PART NUMBER EXPLANATION

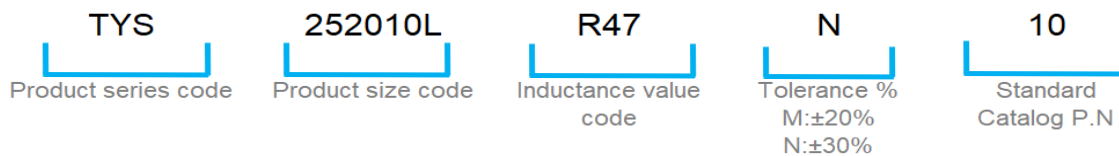

Note:

- 1、 Heat Rated Current (Irms) is tested on a typical PCB and apply a constant current in still air. The temperature rise is dependent on the application system condition including PCB PAD pattern, trace width and thickness and adjacent components etc. It's suggested to verify the temperature rise of the component under the real operation application conditions.
- 2、 shall not be responsible for any defects in products or equipment incorporating such products, which are caused under the conditions other than those specified in this catalog or individual specification.

Drawing	<small>簽署人:</small> <i>Xiaolan Du</i>	Date	6/20/2025 4:44 下午 CST
Check	<small>0D5231F2BEA4411...</small>	Date	
Approval	<small>Signed by:</small> <i>yeatshing.chiang</i>	Date	6/20/2025 4:47 PM CST
	<small>AC48FED8680E418...</small>		

TYS -Low Profile SMT Power Inductor

1.TYS SERIES DIMENSIONS

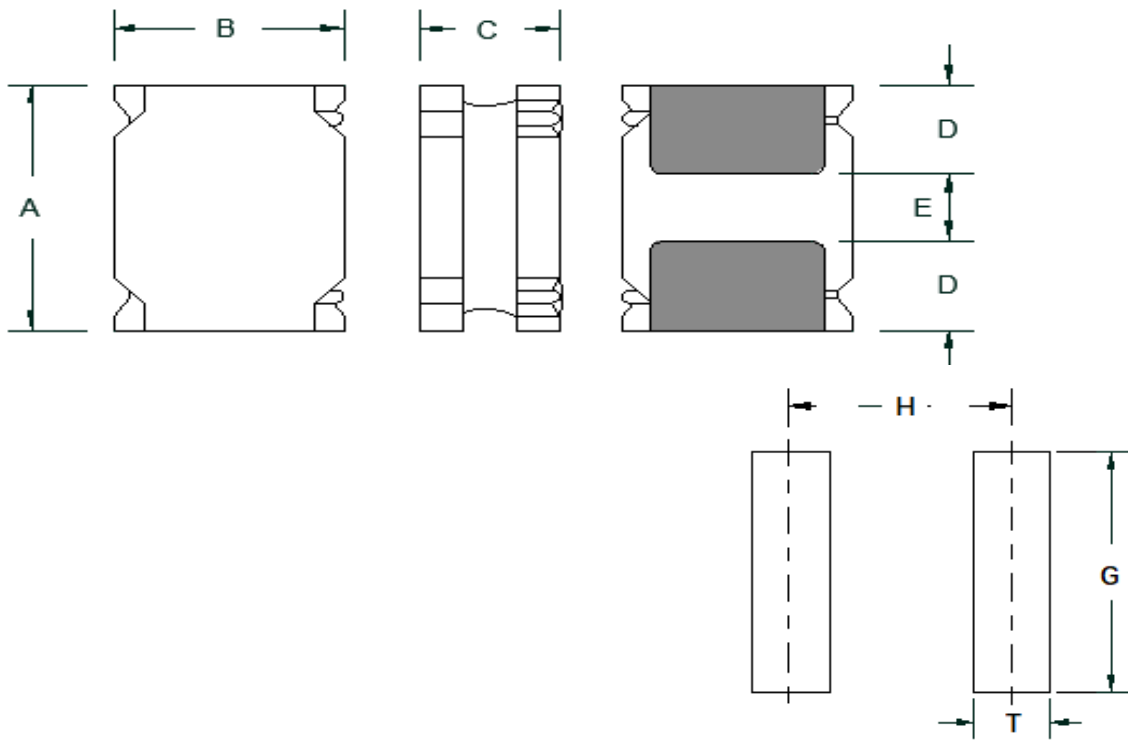

Recommended layout

TYS Size	A	B	C	D	E	G	H	T
252010	2.5±0.3	2.0±0.3	1.0+0.2/-0.3	0.8±0.2	0.8±0.2	2.0Typ	1.65Typ	0.85Typ
252012	2.5±0.3	2.0±0.3	1.2+0.2/-0.3	0.8±0.2	0.8±0.2	2.0Typ	1.65Typ	0.85Typ

TYS -Low Profile SMT Power Inductor

2.SPECIFICATION

PART NUMBER	INDUCTANCE (μ H)	IRMS (A)	ISAT (A) Max	DCR (Ω) Max	SRF MHz
TYS252010LR47N-10	0.47	2.35	2.50	0.056	202
TYS252010LR68N-10	0.68	2.00	2.20	0.074	138
TYS252010L1R0N-10	1.00	1.65	1.85	0.108	100
TYS252010L1R5N-10	1.50	1.30	1.80	0.182	79
TYS252010L2R2N-10	2.20	1.20	1.20	0.209	61
TYS252010L3R3M-10	3.30	0.90	1.05	0.328	48
TYS252010L4R7M-10	4.70	0.70	0.95	0.563	40
TYS252010L6R8M-10	6.80	0.59	0.78	0.896	32
TYS252010L100M-10	10.00	0.50	0.65	1.092	26
TYS252012LR47N-10	0.47	2.15	3.82	0.056	160
TYS252012L1R0N-10	1.00	1.93	2.59	0.083	110
TYS252012L1R5M-10	1.50	1.40	2.24	0.136	97
TYS252012L2R2M-10	2.20	1.15	1.85	0.199	69
TYS252012L3R3M-10	3.30	1.04	1.61	0.244	62
TYS252012L4R7M-10	4.70	0.84	1.12	0.348	47
TYS252012L6R8M-10	6.80	0.69	0.98	0.536	38
TYS252012L100M-10	10.00	0.62	0.79	0.637	34
TYS252012L150M-10	15.00	0.42	0.68	1.469	25
TYS252012L220M-10	22.00	0.38	0.53	1.824	20

- Tolerance: M: \pm 20% or N: \pm 30%
- Inductance tested at 100KHz, 1.0Vrms
- Heat Rated Current (Irms) is defined based on temperature rise approximate 40°C (ambient temperature 25 \pm 5°C)
- Saturation Current (Isat) is the DC current at which the inductance drops off approximately 30% from its value without current. (ambient temperature 25 \pm 5°C)
- Operating temperature range: -40°C~+125°C (including self-heating temperature rise)
- Storage temperature range (packaging conditions): -10°C~+40°C and RH 70%(MAX.)

TYS -Low Profile SMT Power Inductor

3.EQUIVALENT CIRCUIT

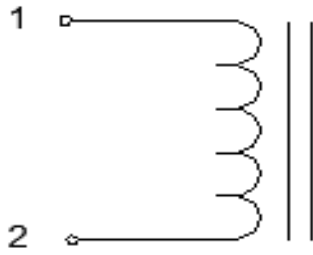

4.MATERIAL LIST

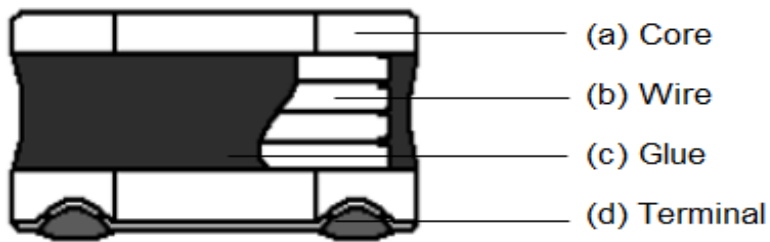

TYS -Low Profile SMT Power Inductor

5. CHARACTERISTICS CURVES

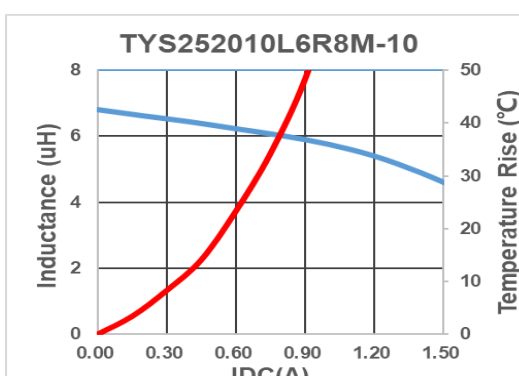
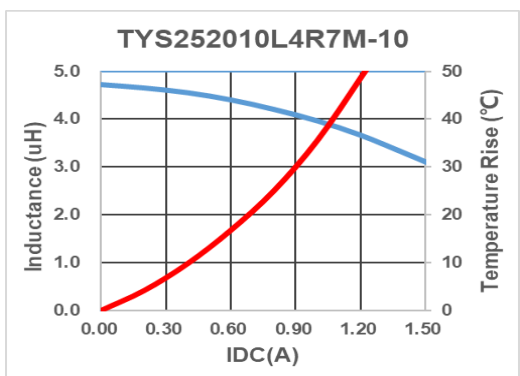
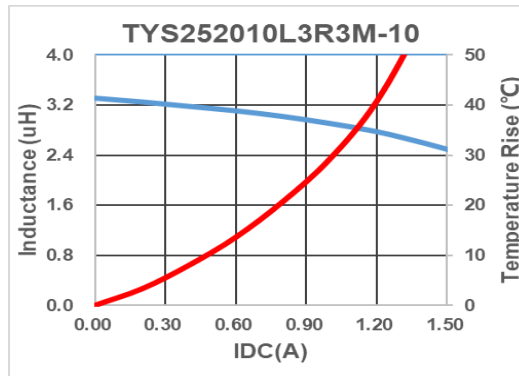
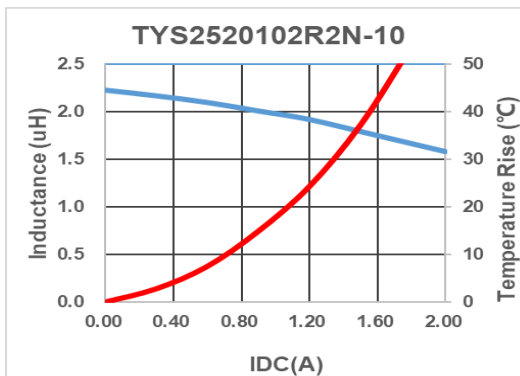
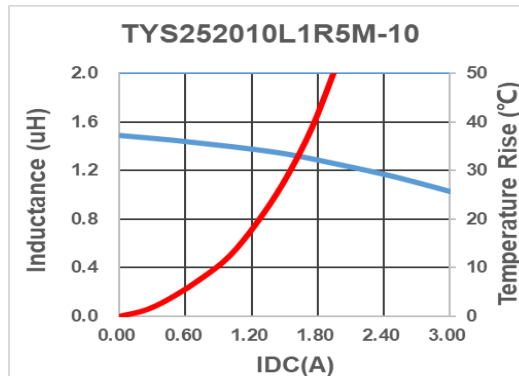
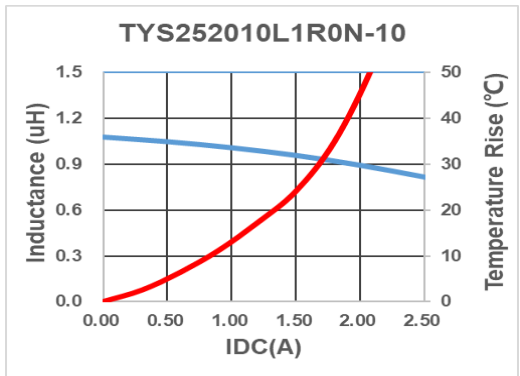
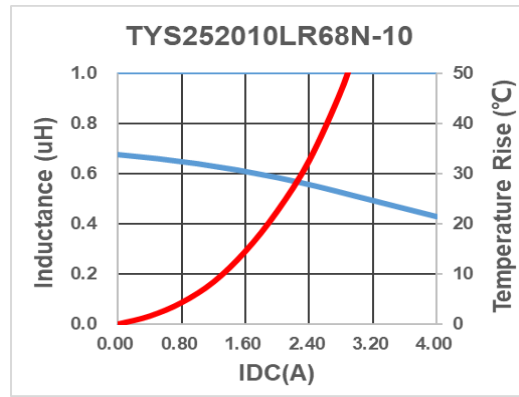
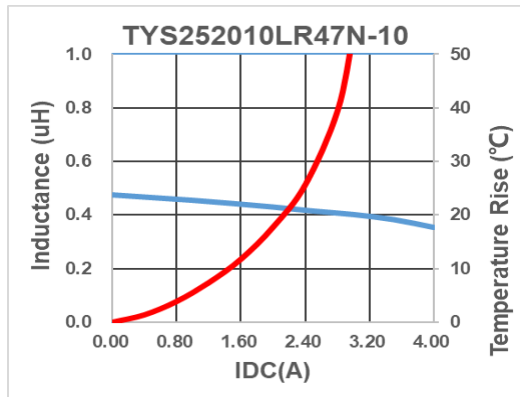

TYS -Low Profile SMT Power Inductor

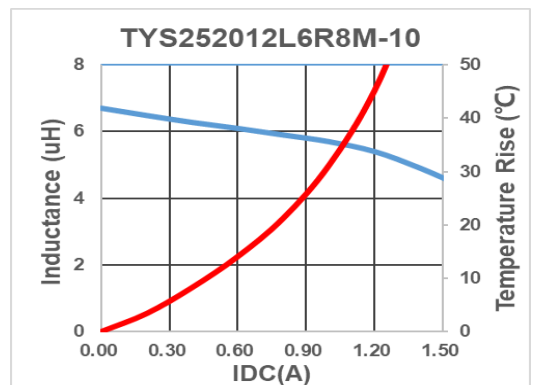
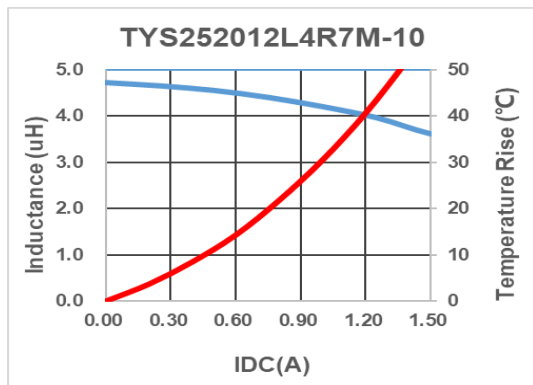
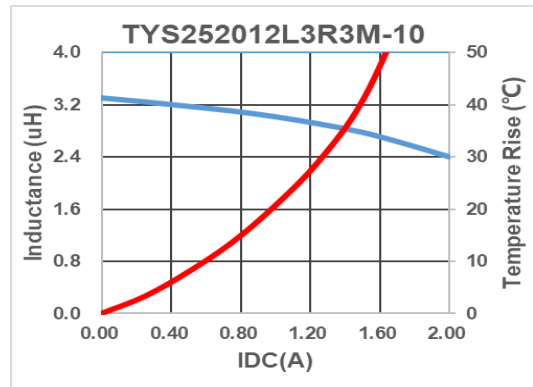
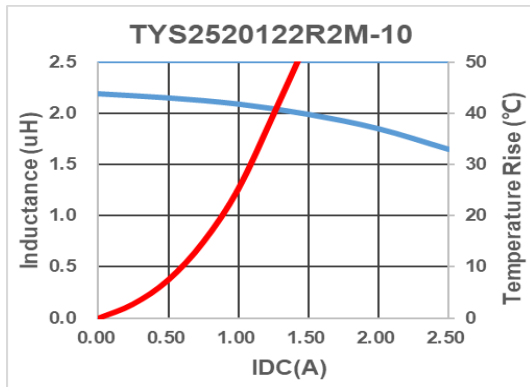
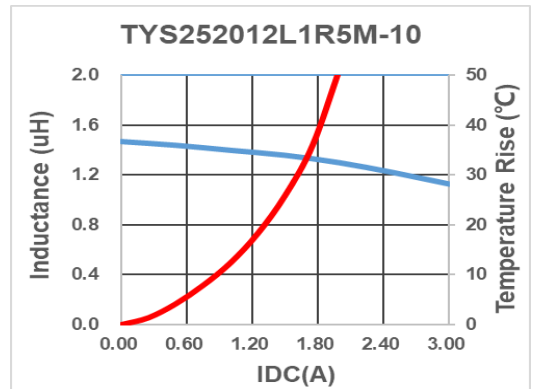
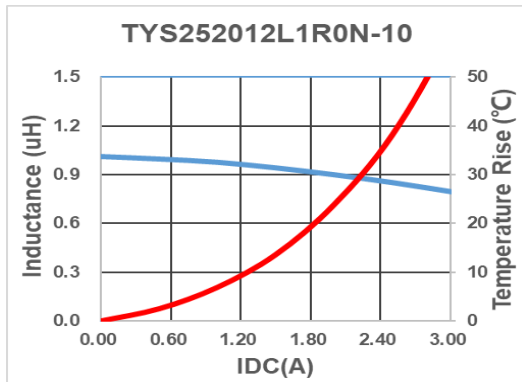
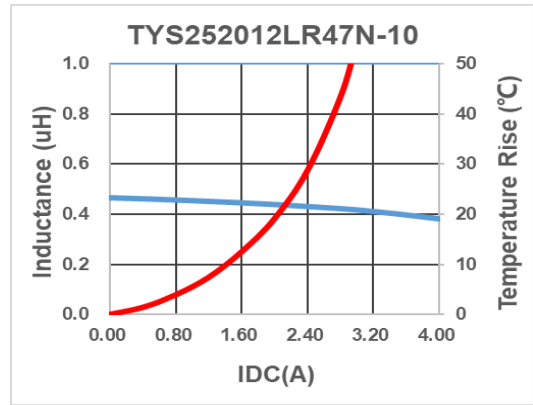
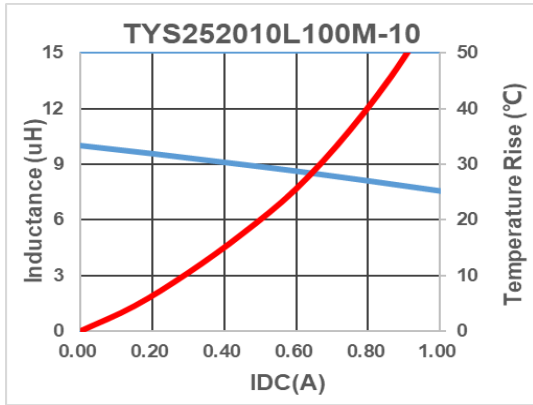

TYS -Low Profile SMT Power Inductor

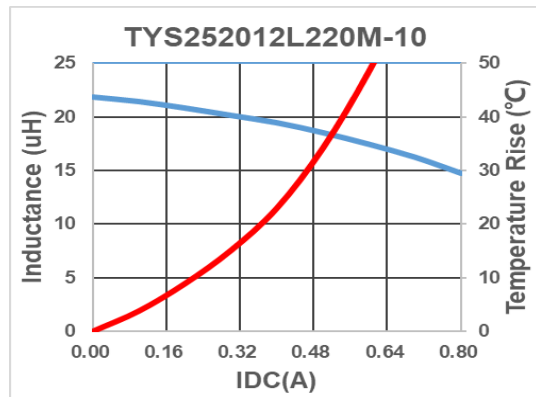
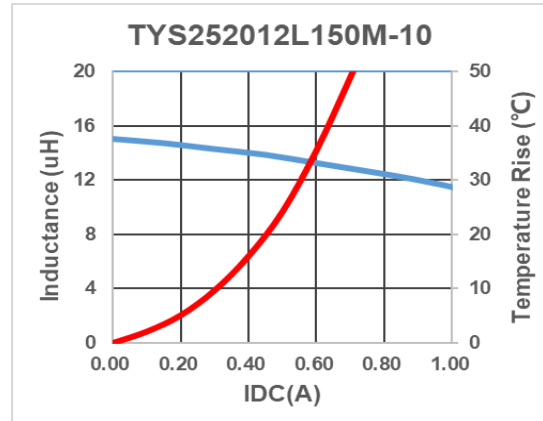
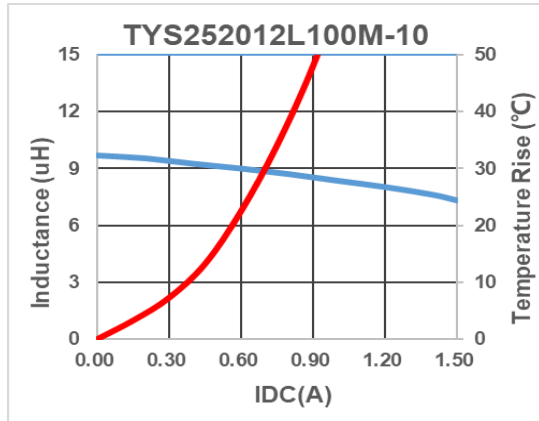

TYS -Low Profile SMT Power Inductor

6. SOLDERING

Mildly activated rosin fluxes are preferred.

Recommended temperature profiles for re - flow soldering in Figure 1 ,Refer to the J-STD-020 standard.

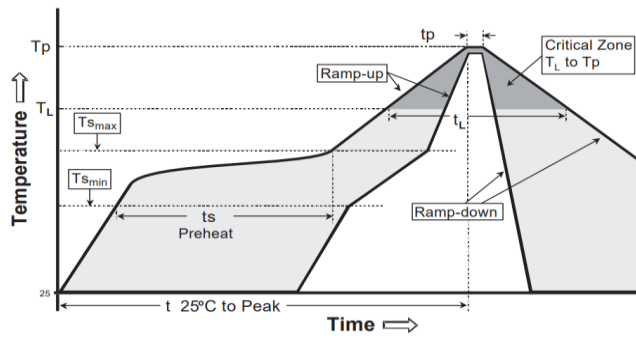

Figure 1

Profile Feature	Sn-Pb Eutectic Assembly	Pb-Free Assembly
Average Ramp-Up Rate (Tsmax to Tp)	3 °C/second max.	3 °C/second max.
Preheat – Temperature Min (Ts min) – Temperature Max (Ts max) – Time (ts min to ts max)	100 °C 150 °C 60-120 seconds	150 °C 200 °C 60-180 seconds
Time maintained above: – Temperature (TL) – Time (tL)	183 °C 60-150 seconds	217 °C 60-150 seconds
Peak/Classification Temperature (Tp)	255°C±5°	255°C±5°
Time within 5 °C of actual Peak Temperature (tp)	10-30 seconds	20-40 seconds
Ramp-Down Rate	6 °C/second max.	6 °C/second max.
Time 25 °C to Peak Temperature	6 minutes max.	8 minutes max.

Note : All temperatures refer to topside of the package, measured on the package body surface.

Reworking should be limited to only one time.

Note : Do not directly touch the products with the tip of the soldering iron in order to prevent the crack on the ferrite material due to the thermal shock.

Solder Volume

Solder shall be used not to be exceed the upper limits as shown below.

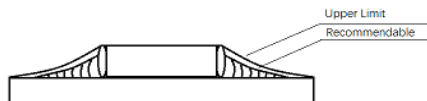

When solder volume is increased ,the mechanical stress to product is also increased . Exceeding solder volume may cause the failure of mechanical or 1 performance.

TYS -Low Profile SMT Power Inductor

7.RELIABILITY

Item	Reference	Additional Requirements
High Temperature Exposure (Storage)	MIL-STD-202 Method 108	85°C, 168 hours , Measurement at 24+/-4 hours after test conclusion.
Temperature Cycling	JESD22 Method JA-104	-40°C to 85°C, 100 cycles, Dwell Time (Soak Time)30 minutes, TransitionTime: 1 minute maximum, Measurement at least24hours after test conclusion
Operational Life	MIL-STD-202 Method 108	85°C, 168 hours, Measurement at 24+/-4 hours after test conclusion., Rated voltage applied
External Visual	MIL-STD-883 Method 2009	Inspect device construction, marking and workmanship. Electrical Test not required.
Physical Dimension	JESD22 Method JB-100	Verify physical dimensions to the applicable device detail specification. Note: Electrical Test not required
Vibration	MIL-STD-202 Method 204	10~55Hz,1.5mm, 2 hours in each 3mutually perpendicular directions (total of 6 hours)
Resistance to Soldering Heat	MIL-STD-202 Method 210	SMD: Condition K, time above 217°C, 60s – 150s, Exposed to two thermal cycles
Solderability	J-STD-002	245±5°C, 5±1sec, Solder: Sn/3.0Ag/0.5Cu
Electrical Characterization	Print Spec	Parametrically test per lot and sample size requirements, summary to show Min, Max, Mean and Standard deviation at room as well as Min and Max Operating temperatures
Board Flex	AEC-Q200-005	2mm(min), Dwell:30±1 sec.
Terminal Strength(SMD)	AEC-Q200-006	Force:10N, Dwell:5+1 sec, X, Y direct

TYS -Low Profile SMT Power Inductor

8. PACKAGING

8-1 Reel Dimension

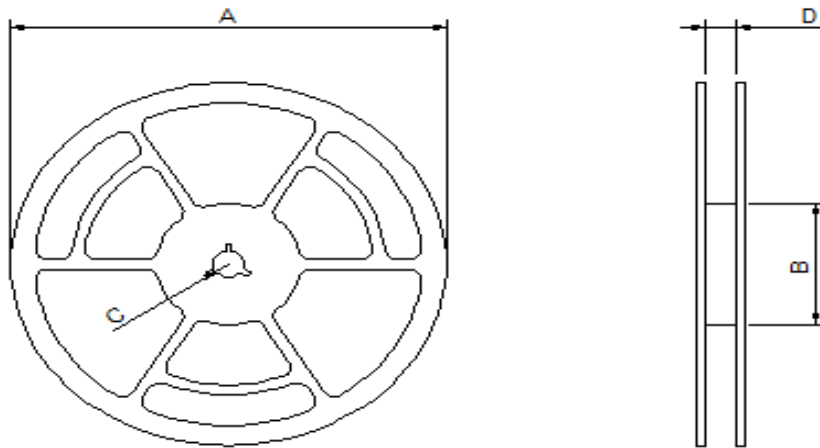

Size	Type	A(mm)	B(mm)	C(mm)	D(mm)
TYS2520	7"mm	180 Ref	60 Ref	13 Ref	8.4 Ref

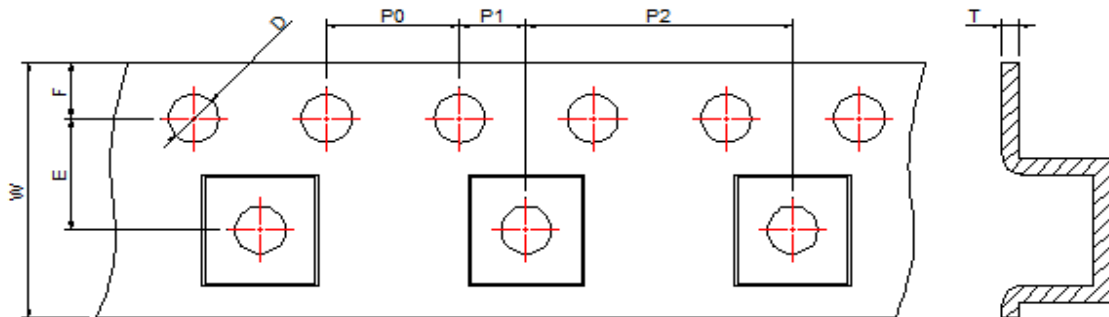

W	E	F	P0	P1	P2	T	D
8.0±0.3	3.5±0.1	1.75±0.1	4.0±0.1	2.0±0.1	4.0±0.1	0.3±0.05	1.5±0.1

Size	Reel	Inner Box	Outer Box
TYS2520	2000	10000	50000

TYS -Low Profile SMT Power Inductor

8-2 Tearing Off Force

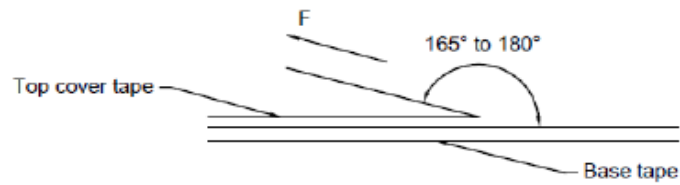

The force for tearing off cover tape is 10~100 grame in the arrow direction under the following conditions .

Room Temp (°C)	Room Humidity(%)	Room atm (hPa)	Tearing Speed mm/min
5~35	45~85	860~1060	300

9. Application Notice:

1.Storage Conditions:

To maintain the solderability of terminal electrodes:

- a) Recommended products should be used within 12 months from the time of delivery .
- b) The packaging materal should be kept where no chlorine or sulfur exists in the air .

2. Transportation:

- a) Products should be -handled with care to avoid damage or contamination from perspiration and skin oils .
- b) Vacuum pick up is strongly recommended for individual components .
- c) Bulk handling should ensure that abrasion and mechanical shock are minimized .