

TYS -Low Profile SMT Power Inductor TYS252012L Series

FEATURES AND APPLICATIONS

Laird **TYS series high current power inductors** improve performance, reliability and power efficiency. A lower profile benefits automotive electronics, industrial and telecom design. Products feature low DCR with greater efficiency and enable extremely compact design. Inductors are of magnetic shielding and wire wound construction and perform in operating temperatures ranging from -40°C to 125°C including self-heating rise in temperature.

FEATURES

- Magnetic shielded structure
- Low DCR and high efficiency
- Low profile and small size
- Automotive grade and meets AEC-Q200



APPLICATIONS

- ADAS, Smart Cockpit, BMS, DCU, general automotive application
- General power line DCDC conversion

PART NUMBER EXPLANATION

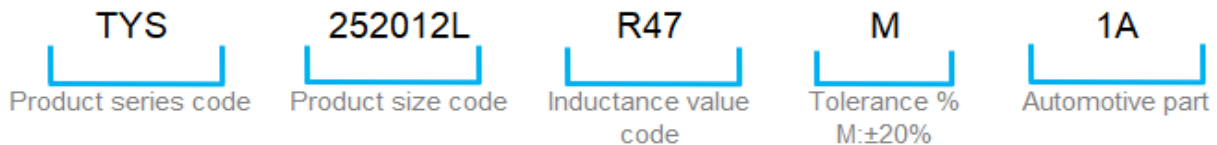

ELECTRICAL SPECIFICATIONS

- Inductance tested at 1MHz, 1.0Vrms
- Heat Rated Current (Irms) is defined based on temperature rise approximate 40°C (ambient temperature 25±5°C)
- Saturation Current (Isat) is the DC current at which the inductance drops off approximately 30% from its value without current. (ambient temperature 25±5°C)
- Operating temperature range: -40°C~+125°C (including self-heating temperature rise)
- Storage temperature range (packaging conditions): -10°C~+40°C and RH 70%(MAX.)

Note:

- 1、 Heat Rated Current (Irms) is tested on a typical PCB and apply a constant current in still air. The temperature rise is dependent on the application system condition including PCB PAD pattern, trace width and thickness and adjacent components etc. It's suggested to verify the temperature rise of the component under the real operation application conditions.
- 2、 PPAP default level 3.

1.TYS SERIES DIMENSIONS

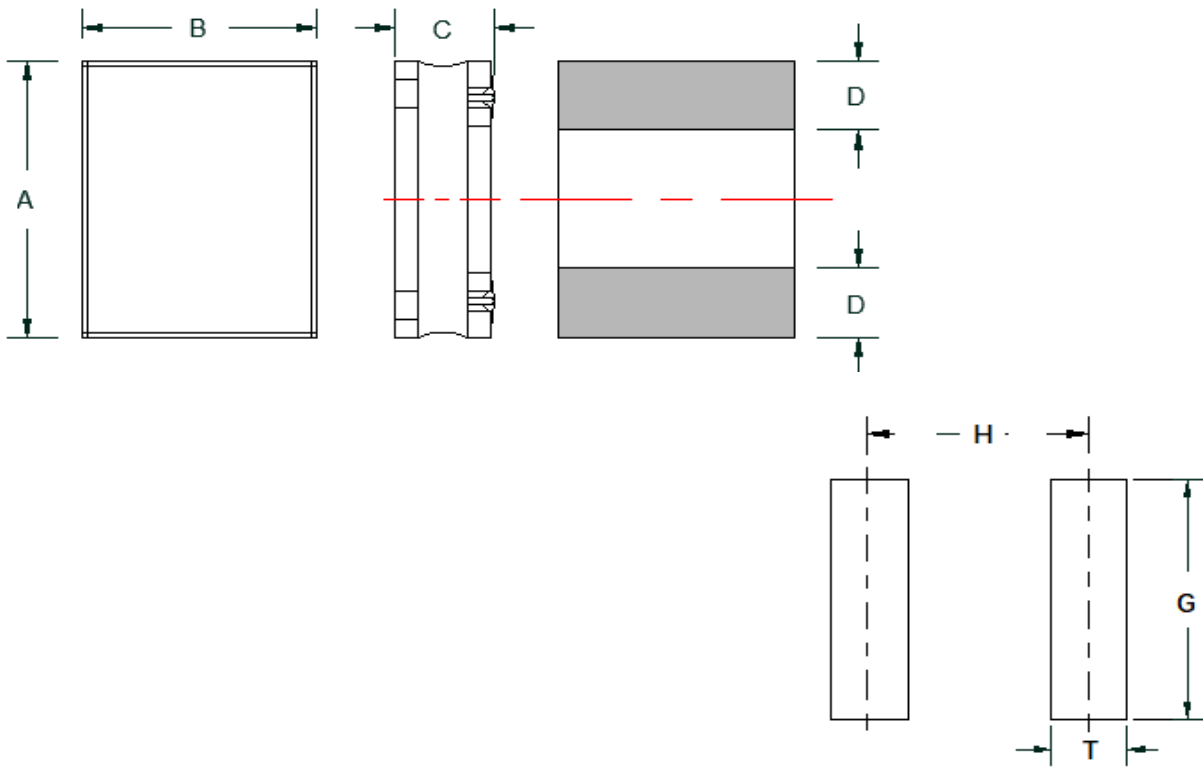

Recommended layout

TYS Size	A	B	C	D	G	H	T
252012	2.5±0.3	2.0±0.3	1.2 +0.2/-0.3	0.8±0.3	2.0Typ	1.65	0.85

2.SPECIFICATION

PART NUMBER	INDUCTANCE□		SRF(MHz) (Min)	ISAT (A) (Max)	IRMS (A) (Max)	DCR (Ω) Max
	Nominal value (μH)	Tolerance (%)				
TYS252012LR47M-1A	0.47	±20	82	3.80	3.00	0.0372
TYS252012L1R0M-1A	1.00	±20	79	2.60	2.40	0.0630
TYS252012L1R5M-1A	1.50	±20	60	2.20	1.81	0.0900
TYS252012L2R2M-1A	2.20	±20	44	1.75	1.70	0.1104
TYS252012L3R3M-1A	3.30	±20	45	1.45	1.42	0.1560
TYS252012L4R7M-1A	4.70	±20	35	1.23	1.29	0.2040
TYS252012L6R8M-1A	6.80	±20	29	1.05	1.00	0.3120
TYS252012L100M-1A	10.00	±20	24	0.83	0.83	0.4560
TYS252012L150M-1A	15.00	±20	18	0.69	0.71	1.0000
TYS252012L220M-1A	22.00	±20	15	0.53	0.54	1.3000

3.EQUIVALENT CIRCUIT

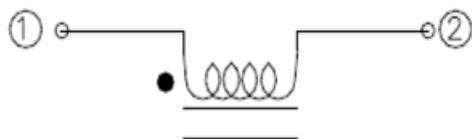

4.MATERIAL LIST

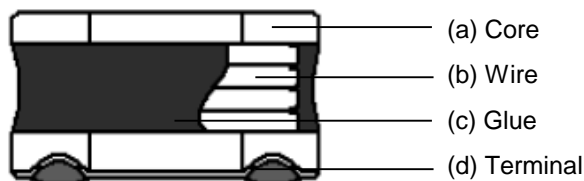

5. CHARACTERISTICS CURVES

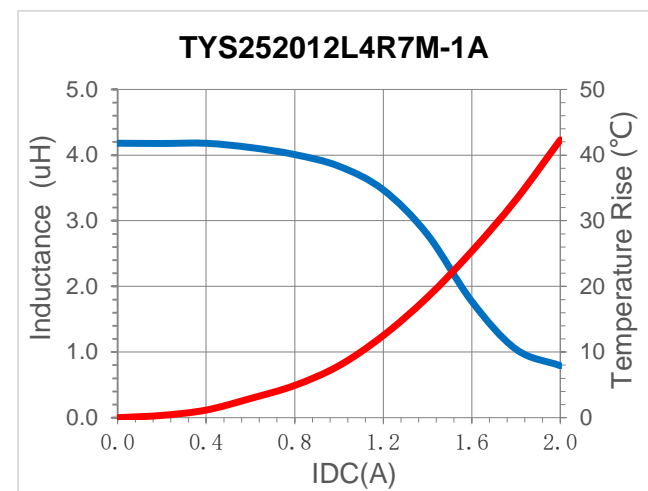
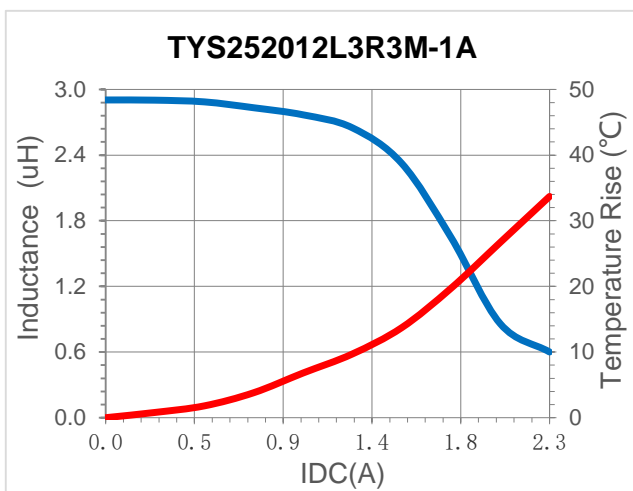
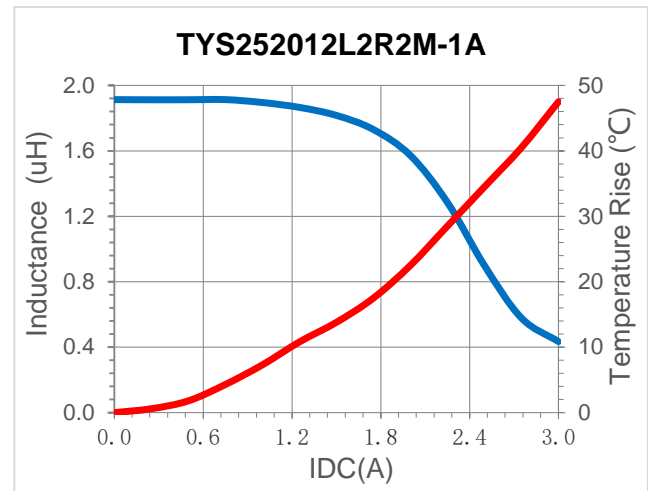
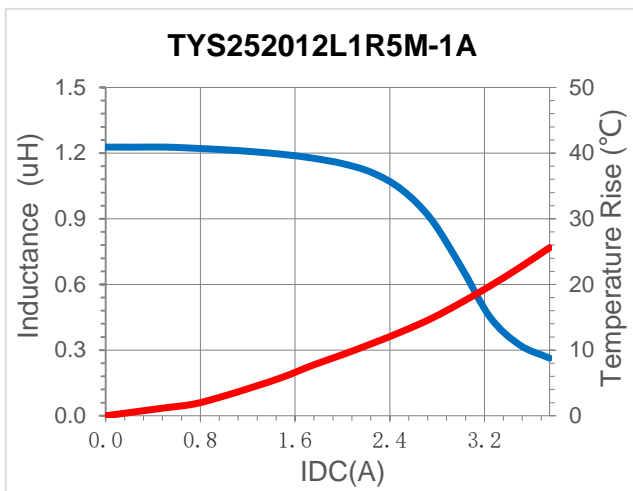
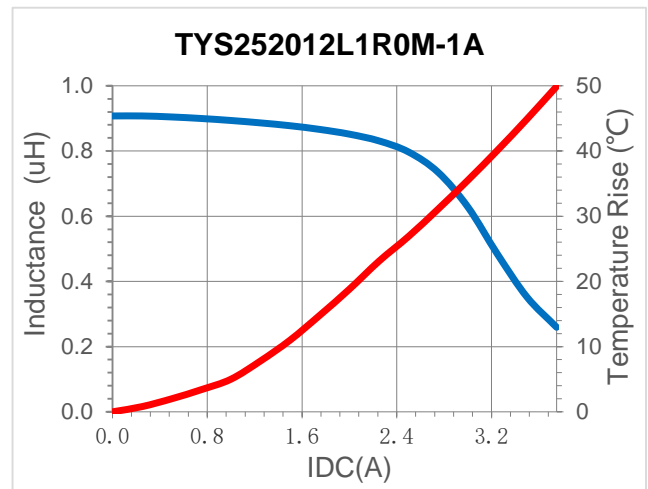
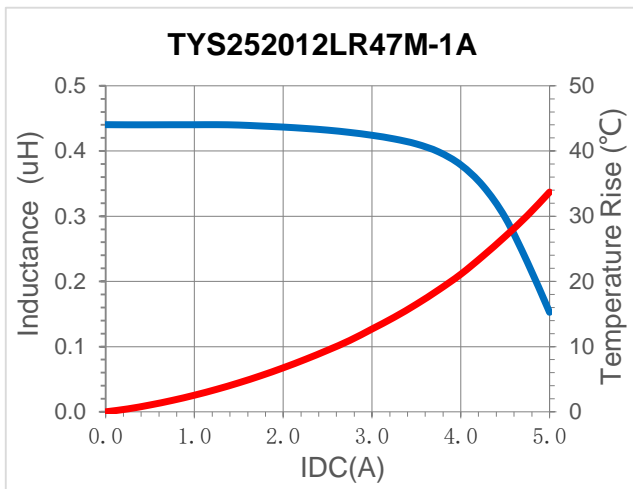

5. CHARACTERISTICS CURVES

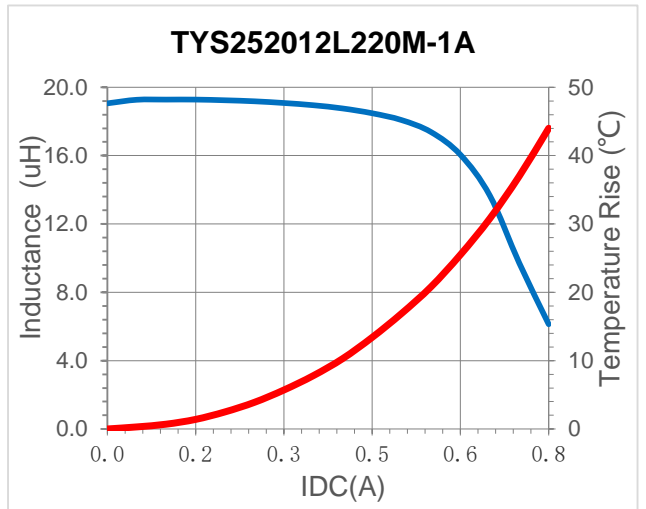
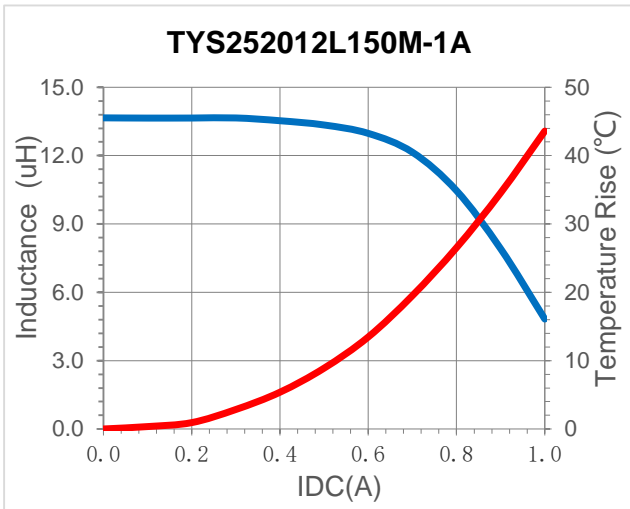
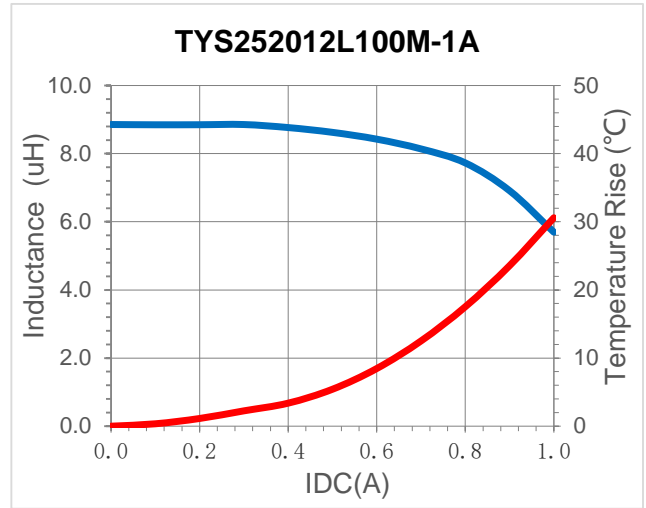
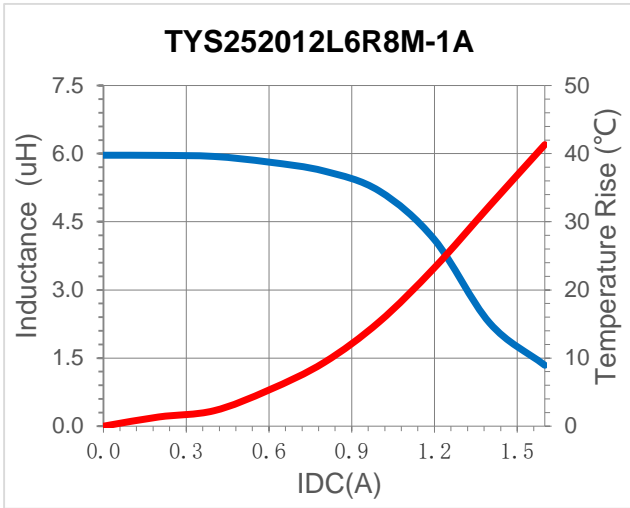

6. SOLDERING

Mildly activated rosin fluxes are preferred.

Recommended temperature profiles for re - flow soldering in Figure 1 .

Temperature Profile

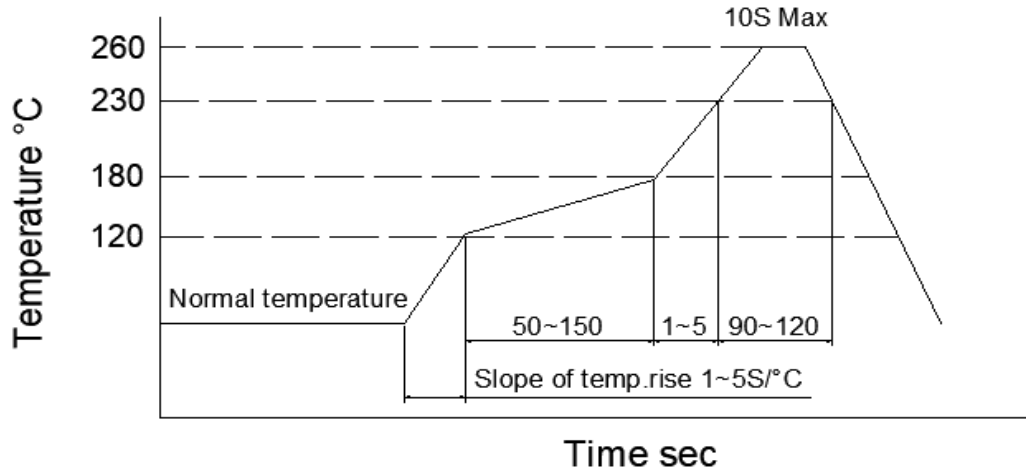

Reworking with soldering iron

Preheating	150°C 1 minute
Tip temperature	280°C max
Soldering time	3 seconds max
Soldering iron output	30w max
End of soldering iron	Φ 3mm max

Reworking should be limited to only one time.

Note : Do not directly touch the products with the tip of the soldering iron in order to prevent the crack on the ferrite material due to the thermal shock.

Solder Volume

Solder shall be used not to be exceed the upper limits as shown below.

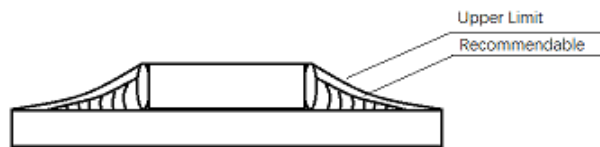

When solder volume is increased ,the mechanical stress to product is also increased . Exceeding solder volum may cause the failure of mechanical or 1 performance.

7.RELIABILITY

Item	Reference	Additional Requirements
Pre- and Post-Stress Electrical Test	Laird Specification	Test is performed at room temperature except as specified in the applicable stress reference and the additional requirements in this Table.
High Temperature Exposure (Storage)	MIL-STD-202 Method 108	Unpowered. 1,000 hours. Upper Temperature: maximum specified operating temperature or maximum specified storage temperature (whichever is higher). Measurement at 24±4 hours after test conclusion.
Temperature Cycling	JESD22-A104	Unpowered. 1,000 Cycles. Lower Temperature of the Chamber: -40°C. Upper Temperature of the Chamber: maximum specified operating temperature and shall not exceed 125°C. Dwell Time (Soak Time):15 minutes minimum,30 minutes minimum if component weighs above 28g. Transition Time: 1 minute maximum. Measurement at least 24 hours after test conclusion.
Humidity Bias	MIL-STD-202 Method 103	Unpowered. 1,000 hours, 85°C/85%RH. Measurement at 24±4 hours after test conclusion.
High Temperature Operating Life	MIL-STD-202 Method 108	1,000 hours. Upper Temperature of the Chamber: maximum specified operating temperature (not including heat rise) at maximum rated current and shall not exceed 125°C. Measurement at 24±4 hours after test conclusion.
External Visual	MIL-STD-883 Method 2009	Inspect device construction, marking and workmanship. Pre and Post Electrical Test not required.
Physical Dimensions	JESD22-B100	Verify physical dimensions to the applicable component detail specification. Pre and Post Electrical Test not required.
Mechanical Shock	MIL-STD-202 Method 213	Figure 1 of Method 213. SMD: Condition C. Tested per the Supplier's recommended mounting method.
Vibration	MIL-STD-202 Method 204	5g's for 20 minutes 12 cycles each of 3 orientations. Tested per the Supplier's recommended mounting method. Verification of transfer load: during setup, verify that with the selected PCB design (size, thickness and secure points), or an alternative mount, that the transferred load onto the component corresponds to the requested load. This verification can be achieved using a laser vibrometer or other adequate measuring device. Test from 10 Hz - 2000 Hz.
Resistance to Soldering Heat	MIL-STD-202 Method 210	SMD: Condition K, time above 217°C, 60s – 150s Non-soldered type mounting/attach are not applicable

RELIABILITY

Item	Reference	Additional Requirements
Solderability	J-STD-002	SMD: Method B1, Coating Durability Category 2 Method D, Coating Durability Category 2 Note: in particular circumstances when SnPb reverse compatibility is requested by the User. Method B shall be used for SMD. Magnification 50x Pre and Post Electrical Test not required. Non-soldered type mounting/attach are not applicable.
Electrical Characterization	Laird Specification.	Parametrically test per lot and sample size requirements,(inductance only unless otherwise agreed upon) Summary to show minimum, maximum, mean and standard deviation at room operating temperatures. Pre and Post Electrical Test not required
Board Flex (SMD)	AEC-Q200-005	
Terminal Strength (SMD)	AEC-Q200-006	

7. PACKAGING

7-1 Reel Dimension

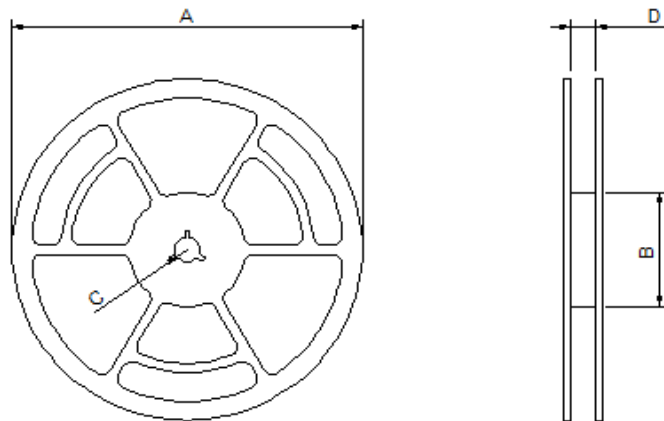

Size	Type	A(mm)	B(mm)	C(mm)	D(mm)
TYS252012	7"mm	180 Ref	60 Ref	13 Ref	8.4 Ref

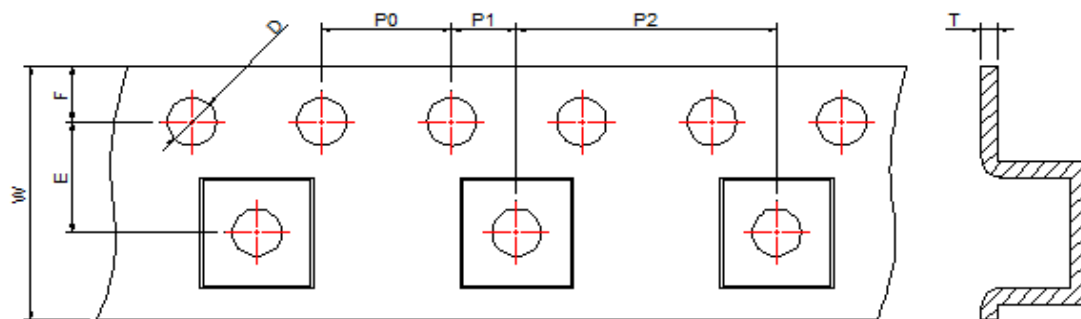

W	E	F	P0	P1	P2	T	D
8.0±0.3	3.5±0.1	1.75±0.1	4.0±0.1	2.0±0.1	4.0±0.1	0.3±0.05	1.5±0.1

Size	Reel	Inner Box	Outer Box
TYS252012	2000	10000	50000

7-2 Tearing Off Force

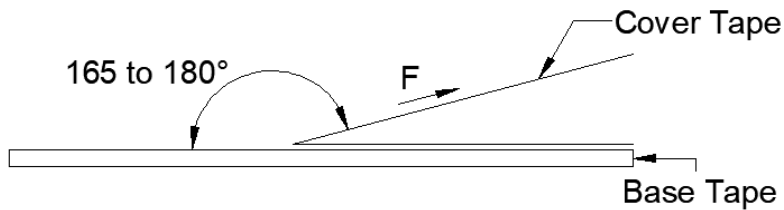

The force for tearing off cover tape is 10~100 grame in the arrow direction under the following conditions .

Room Temp (°C)	Room Humidity(%)	Room atm (hPa)	Tearing Speed mm/min
5~35	45~85	860~1060	300

8. Application Notice:

1.Storage Conditions:

To maintain the solderability of terminal electrodes:

- a) Recommended products should be used within 12 months from the time of delivery .
- b) The packaging material should be kept where no chlorine or sulfur exists in the air .

2. Transportation:

- a) Products should be -handled with care to avoid damage or contamination from perspiration and skin oils .
- b) Vacuum pick up is strongly recommended for individual components .
- c) Bulk handling should ensure that abrasion and mechanical shock are minimized .